

## Project Information Sheet

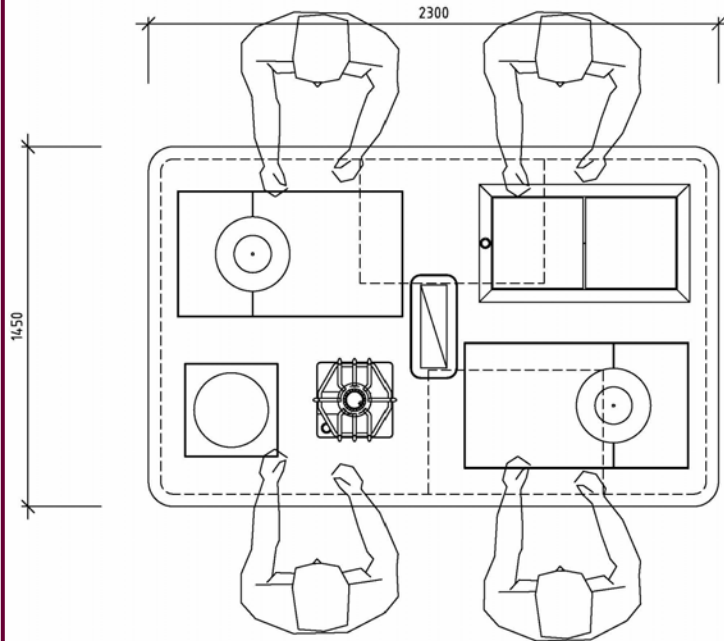

**ATHANOR SUITES**  
 CREATEUR ET CONCEPTEUR DE FOURNEAUX SUR MESURE

**Location:**

20 Queen Street, London W1J 5PR

Ground floor 60 cover restaurant with area for private dining with view into kitchen

**Suite details:**

2300mm long x 1450mm wide comprising:  
 1x single radiant hob, 1x 6kW open burner, 2x 900mm 12kW gas solid top, 1x 2 zone 'Plaque Athanor' plancha, 2x 1/1Gn gas oven, 1x single width pan storage cupboard.

**Case Study**

"Awesome" declared one restaurant critic on the recent opening of Murano, part of Gordon Ramsay Holdings. Angela Hartnett (Chef Patron) and Diego Cardoso (Head Chef) have very quickly turned the restaurant into a 'must dine' venue in London's Mayfair, and picked up a Michelin star only 4 months since opening.

The opulent restaurant with its Italian styled interior is supported from what is a very small kitchen, partly on-view from an area which can be set aside for private dining - when not needed as part of the main restaurant seating.

Centrally within the kitchen is an Athanor island bespoke suite utilising 2x traditional gas solid tops, 1x double 'Plaque Athanor Plancha', 1x radiant and 1x open burner. "We use the open burner during mise-en-place for stock work - but come service it's covered over to give us more service space" Diego (Head Chef) comments. "The kitchen is very tight and left us with a very small footprint for the suite - ultimately it works very well. We have plenty on heat sources for mise-en-place and then individual working zones during service" adds Chef.

Signature

FSE LIMITED