

## Project Information Sheet

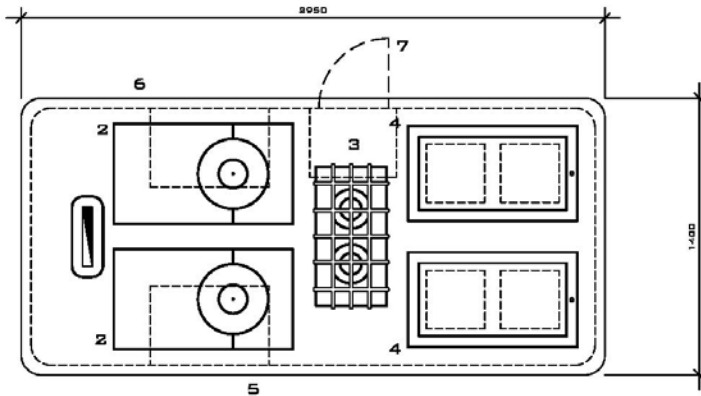

**ATHANOR SUITES**  
 CREATEUR ET CONCEPTEUR DE FOURNEAUX SUR MESURE

**Location**

12 Waterloo Place, London SW1Y 4AU

*Basement: Back of house area including kitchens*

*Ground Floor: Main bar, main restaurant seating for up to 70, and private dining room*

*First Floor: Restaurant seating for up to 40 covers (area can be sub-divided for functions)*

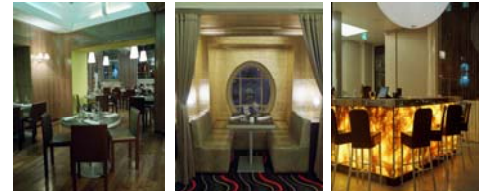
**Case Study**

Acclaimed Michelin starred chef's **Jacques & Laurent Pourcel** commissioned an Athanor suite for their first restaurant venture in London.

The configuration of the suite required ultimate flexibility for the mise-en-place period and precision cooking for the service period.

The suite configuration combines the need for large volume heat surfaces for stock production during preparation periods and ambient lay-off zones for resting product during service.

The suite comprises two solid tops, two open burners, two 'Plaque Athanor' Plancha and one oven to service a 120 cover restaurant.

Athanor was chosen due to the efficient design and multi-functional cooking elements which could be incorporated within a compact footprint.

Signature

FSE LIMITED